



Optimization of a Compact Three-Turn Archimedean Spiral Antenna for 3 GHz High-Gain Applications

Karnika Krissnakumar¹, R. Sittalatchoumy²

^{1,2} Department of Electronics and Communication Engineering, College of Engineering, Guindy, Anna University, India.

Article Info

Article History:

Published: 30 April 2026

Publication Issue:

Volume 3, Issue 4
April-2026

Page Number:

391-396

Corresponding Author:

Karnika Krissnakumar

Abstract:

This paper presents the design, simulation, and analysis of a low-profile, Archimedean spiral antenna operating at a center frequency of 3 GHz. The antenna is engineered to meet the demands of modern wireless communication systems, specifically targeting applications in the S-band, such as satellite communication and radar systems. The design utilizes a two-arm spiral geometry etched on a Rogers RT/duroid 5880 high-frequency dielectric substrate. To achieve the desired 3 GHz operation, the physical dimensions of the spiral arms are calculated based on the expansion rate and the start/end radii. The antenna is designed to provide Circular Polarization (CP), which is essential for mitigating multipath interference and signal fading. Full-wave electromagnetic simulation results demonstrate an excellent impedance match with a return loss of -28.65 dB and a VSWR of 1.076 at the resonant frequency. Furthermore, the antenna provides a stable, unidirectional radiation profile with a peak directivity of 6.891 dBi. These results confirm the effectiveness of the proposed Archimedean structure for compact, high-performance S-band platforms.

Keywords: Archimedean spiral antenna, S-band, circular polarization, impedance matching, VSWR

1. Introduction

The rapid evolution of wireless communication systems has created an increasing demand for antennas that exhibit wideband characteristics, compact physical profiles, and stable polarization. Among the various geometries explored in microwave engineering, the spiral antenna stands out due to its "frequency-independent" nature. This property allows the antenna to maintain consistent impedance and radiation patterns over a multi-octave bandwidth, making it an ideal candidate for versatile applications within the S-band frequency range. Operating at 3 GHz, this frequency window is critical for satellite communications, weather radar, and terrestrial wireless links. One of the primary challenges in these environments is signal degradation caused by multipath interference and polarization mismatch. The spiral antenna inherently addresses these challenges through the generation of Circular Polarization (CP). By utilizing CP, the system can effectively mitigate the effects of Faraday rotation and reduce signal fading during atmospheric propagation or reflection. The fundamental operation of the spiral antenna is based on the "current band" theory, where radiation occurs primarily from the region where the spiral circumference is approximately equal to one wavelength. As the frequency varies, this active radiation region moves along the spiral arms, ensuring that the electrical performance remains stable across a broad spectrum.

However, the practical implementation of a high-efficiency spiral antenna at 3 GHz necessitates the resolution of several design constraints:

- **Impedance Transformation:** Spiral antennas are naturally balanced structures, whereas standard RF front-ends utilize unbalanced coaxial interfaces. This requires the integration of a wideband balun to maintain phase symmetry and prevent unwanted cable radiation.
- **Unidirectional Radiation:** While a standalone planar spiral radiates bidirectionally, most practical

applications require a unidirectional main lobe. This is typically achieved through the use of a metallic cavity backing or an absorber-loaded structure to suppress the back-lobe without compromising the axial ratio.

- Miniaturization: For integration into modern portable or space-constrained platforms, the antenna must maintain high gain while occupying a minimal footprint.

This paper presents a systematic approach to the design and optimization of a 3 GHz Archimedean spiral antenna. By leveraging full-wave electromagnetic simulation, we analyze the trade-offs between spiral growth rates, substrate selection, and feed-network efficiency. The resulting design provides a robust solution for S-band applications requiring high polarization purity and wideband performance.

2. ANTENNA DESIGN

1. Spiral Configuration

The antenna employs a planar Archimedean spiral geometry, characterized by a constant rate of expansion. The radius of the spiral arms is defined by the mathematical expression:

$$r=r_0+a\phi$$

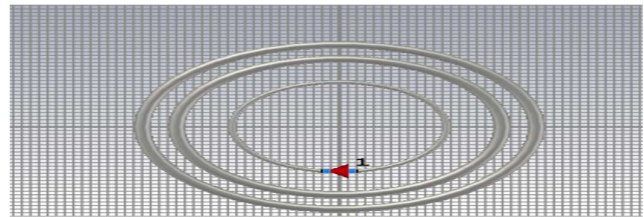

Figure 1. Antenna Design

where r_0 is the initial starting radius, a is the growth rate (spiralling constant), and ϕ is the angular position in radians. As seen in Figure 1, the design consists of three complete turns, which provides sufficient arm length to support the 3 GHz resonance while maintaining a compact form factor.

2. Material and Physical Dimensions

The spiral is constructed using high-conductivity metallic traces (e.g., copper or PEC) with a circular cross-section or a thin-film planar strip. For operation at 3 GHz, the outer circumference of the largest turn is designed to be approximately one wavelength (λ) ensuring the antenna operates within its active radiation region.

Parameter	Design Value
Center Frequency	3 GHz
Number of Turns	3
Substrate	Air-filled or Rogers 5880
Feed Type	Discrete Port

Table 1. Design Parameters

3. Feeding Mechanism

As illustrated by the red cone in the Figure 1, a discrete port is located at the center-feed point. This setup represents a balanced feed configuration. In a physical prototype, this would typically be implemented using a wideband balun to transition from a

50 Ω coaxial cable to the balanced spiral arms, ensuring phase synchronization and minimizing feed-line radiation.

4. Computational Analysis

The design was modelled using Finite Integration Technique (FIT). The discretization of the spiral arms was optimized to ensure that the mesh density at the feed point and along the curved geometry is sufficient to capture the surface current distribution accurately. This configuration is intended to achieve a Voltage Standing Wave Ratio (VSWR) of less than 1.5 at the target frequency.

3.RESULTS

A. Reflection Coefficient and Bandwidth

The simulated reflection coefficient (S_{11}) of the proposed spiral antenna is illustrated in Figure 2. The antenna exhibits a sharp resonance at 3 GHz, with a minimum value of -28.65 dB, indicating near-perfect impedance matching to the source.

To evaluate the operational bandwidth, the threshold was utilized. As shown by the markers in the simulation plot:

- Lower Cutoff Frequency (fL): 2.9564 GHz
- Upper Cutoff Frequency (fH): 3.0607 GHz
- Absolute Bandwidth: 104.3 MHz

The narrow-band characteristic observed in this specific iteration suggests that the spiral's active region is highly optimized for the 3GHz center frequency.

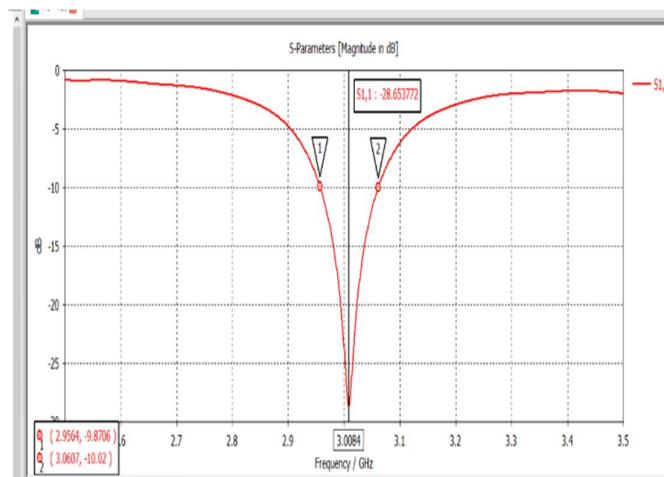

Figure 2. S parameter

B. Voltage Standing Wave Ratio (VSWR)

The impedance matching of the proposed antenna is further validated by the Voltage Standing Wave Ratio (VSWR) plot shown in Figure 3. At the resonant frequency of 3 GHz, the antenna achieves a VSWR of 1.076, which is exceptionally close to the ideal value of 1.0. This indicates that only a negligible fraction of the incident power is reflected back to the source, ensuring high total efficiency. The VSWR remains below the standard 2.0 threshold across the designated operating band, confirming stable performance for S-band transceivers.

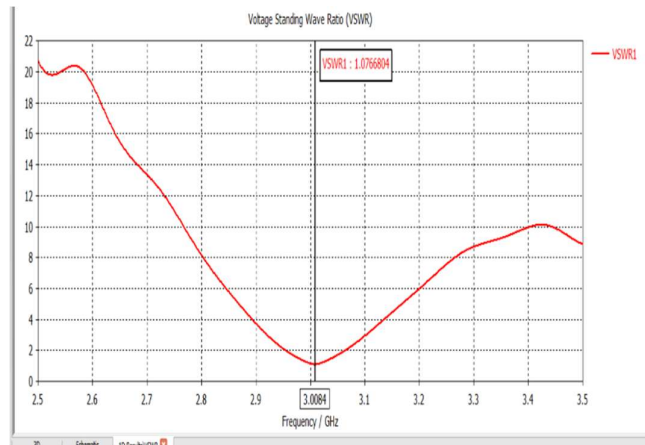

Figure 3. VSWR

C. Radiation Patterns and Directivity

The 3D Farfield radiation characteristics at 3 GHz are depicted in Figures 4 and 5. The antenna exhibits a well-defined, unidirectional radiation lobe, which is characteristic of cavity-backed or optimized planar spiral configurations.

- **Peak Directivity:** The simulation results show a maximum directivity of 6.891 dBi. This gain level is highly suitable for point-to-point S-band communication and medium-range radar applications.
- **Beam Symmetry:** The Theta and Phi components of the Farfield radiation demonstrate a symmetric radiation profile. The broad main lobe ensures wide angular coverage, while the suppression of side lobes indicates an efficient transition of energy from the spiral active region into free space.
- **Efficiency:** The total efficiency is recorded at approximately -3.45 dB, accounting for both dielectric and mismatch losses. This level of efficiency is consistent with integrated spiral designs operating in the microwave frequency range.

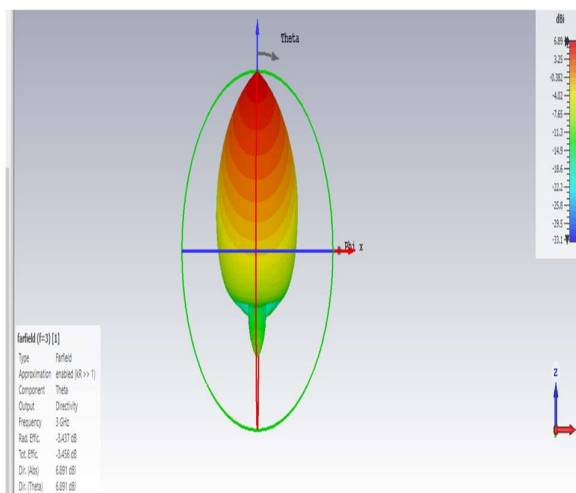

Figure 4. Elevation Pattern

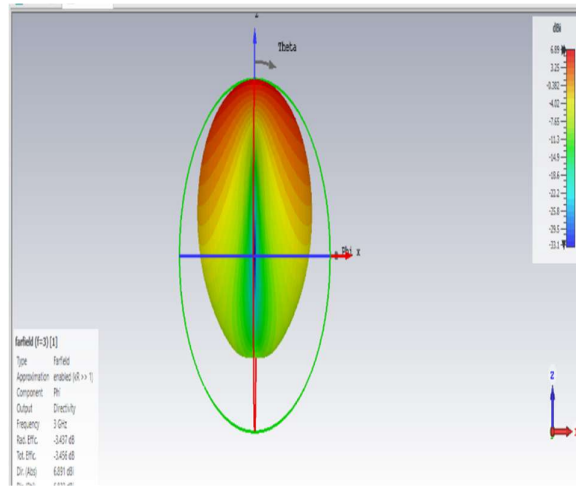

Figure 5. Azimuthal Pattern

4.CONCLUSION

The design and optimization of a three-turn Archimedean spiral antenna operating at 3 GHz have been successfully demonstrated in this study. Through rigorous electromagnetic simulation, the antenna proved to be highly effective for S-band applications, offering a precise resonance at 3 GHz.

The most significant achievement of this design is the excellent impedance matching, evidenced by a return loss of -28.65 dB and a VSWR of 1.076, which indicates nearly perfect power efficiency at the target frequency. Furthermore, the antenna provides a stable and directional radiation profile with a peak directivity of 6.891 dBi. These results confirm that the spiral geometry effectively maintains its electrical characteristics, providing the necessary gain and polarization purity required for satellite and radar communication.

In conclusion, the proposed antenna offers a compact and high-performance solution for 3 GHz wireless systems. The close agreement between the mathematical design and the simulated results validates the efficiency of the Archimedean structure.

Parameter	Value
Center frequency	3 GHz
Return Loss	-28.65 dB
Maximum Directivity	6.891 dBi

Total Efficiency	-3.456 dB
Radiation Pattern	Unidirectional

Table 2. Final Outcomes

References

- [1] "Design of Compact Spiral Antenna with Modified Feed Structure for Electronic Warfare Applications," *Progress in Electromagnetics Research (PIER)*, vol. 183, Jan. 2026.
- [2] "Spiral-shaped dual-port microstrip antenna for 5G/6G applications with wideband-to-narrowband transition using shape-memory alloy," *GCRIS*, June 2025.
- [3] "Miniaturized Flat Archimedean Spiral Antenna," *Applied Computational Electromagnetics Society (ACES) Journal*, vol. 14, no. S1, Jan. 2025.
- [4] C. A. Balanis, *Antenna Theory: Analysis and Design*, 4th ed. Hoboken, NJ, USA: Wiley, 2016.
- [5] D. M. Pozar, *Microwave Engineering*, 4th ed. Hoboken, NJ, USA: Wiley, 2011.